

PRODUCT FEATURES

Constructed of corrosion resistant materials suitable for installation in virtually any location.

Compact footprint.

Baffle structure retains separated grease increasing retention efficiency of separator.

Includes one ECALA-TZ-18 Extension Collar Adapter Lid Assembly for in-ground installation.

Included lid rated for foot-traffic only

SPECIFICATIONS

Construction: _____ Single-Piece Rotationally Molded Polyethylene Exterior Tank with Inlet/Outlet Inverts secured using Patented Interior Radial Compression Ring

Flow Rating: _____ 75 GPM (4.73 l/s)

Liquid Capacity: _____ 70 gallons (265 l)

Grease Capacity: _____ 55 gal. (208.2 l)
405.6 lbs. (184 Kg)

Solids Capacity: _____ 22.6 gallons (85.6 l)

Inlet/Outlet: _____ 4" (101 mm)

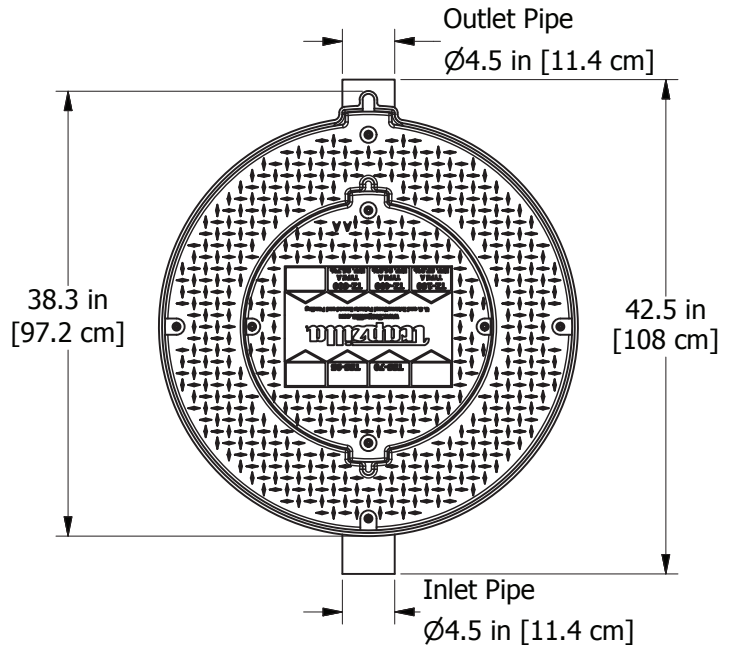

10 in [25.4 cm] CLEARANCE FROM TOP OF TANK REQUIRED FOR LID REMOVAL

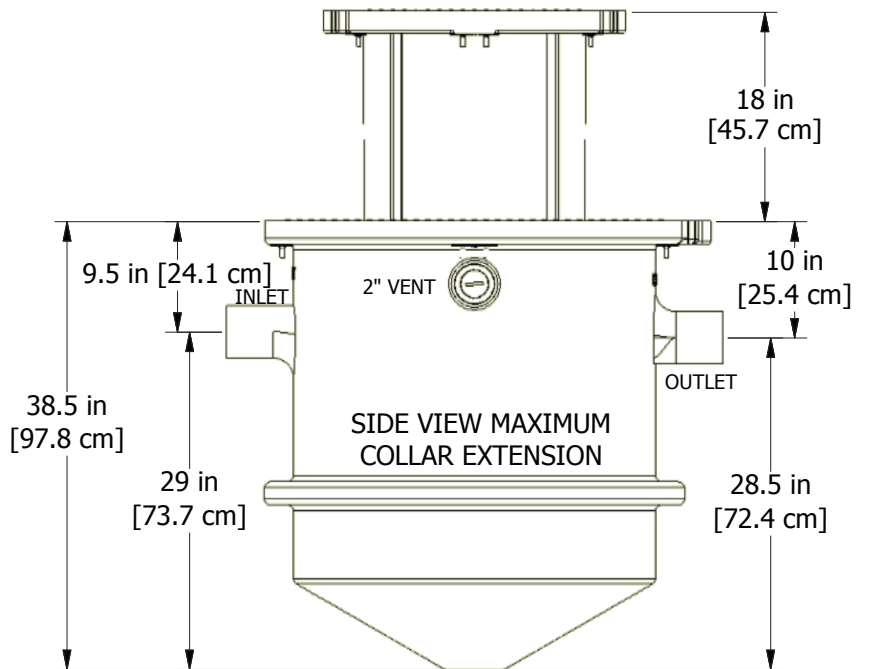
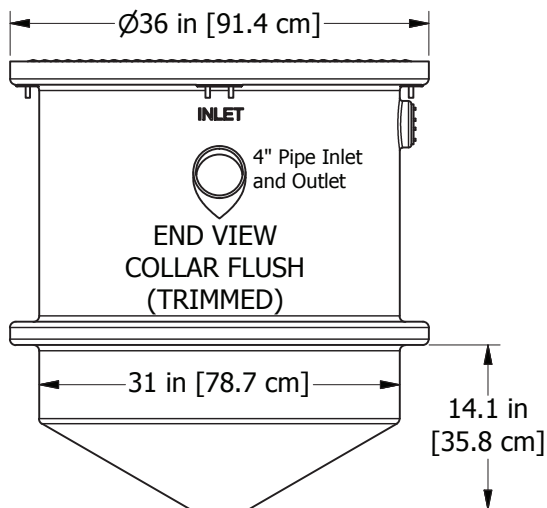



Trapzilla® Grease Interceptor

TZ-400-ECA Specifications

NOTES

1. READ instruction manual included with system before installing/operating.
2. Unit requires 6" (15.24 cm) of clearance all the way around the lid from walls or other structures to allow for servicing.
3. Make piping connections with rubber "No Hub" connectors.
4. Keep outlet piping as straight as possible. Use only "sweep" connections.
5. Install vent on outlet piping.
6. If installing in conjunction with other Trapzilla products, include cleanout port before, after, and/or between each unit.
7. Do not install "P" Trap on outlet connection of tank (unit already has internal gas trap).
8. Do not reduce pipe size on outlet piping
9. Do not pressure test unit.

Equipment must be installed in compliance with all applicable laws, regulations and codes, including plumbing codes. Installation should be performed by a qualified plumbing contractor.

JOB SPECIFICATION

Grease separator(s) shall be Aqua Mundus **Trapzilla** hydromechanical grease interceptor system(s) as manufactured by Thermaco, Inc., Asheboro, North Carolina as noted on plans.

SEPARATOR SPECIFICATIONS

Furnish and install _____ Aqua Mundus Trapzilla Model No. TZ-400-ECA, rotationally molded polyethylene grease interceptor(s) for above or below ground installation, shall be rated at 75 GPM (4.73 l/s) with 55 gal. (208.2 l) / 405.6 lbs. (184 Kg) of total grease storage capacity with flat separation efficiency curve capable of holding 79% of volume in free-floating fats, oils, and grease at capacity, with removable cover for grease and solids removal access, integral anti-flotation anchor ring for in-ground installation, integral horizontal baffle, laminar inlet flow diverter, integral vessel vent, separate storage compartments for grease and heavier than water solids, a unitary tank body and 4" (101 mm) inlet/outlet structures without gasket interfaces, utilizing an interior radial compression ring conjoining invert to tank outlet/inlet structures without bulkhead fittings and/or gaskets, invert top and bottom secured attachment points, sloping conical bottom for solids retention, integral sewer gas trap, and a fully removable polyethylene self-positioning cover with sealed thread fasteners. Includes one extension collar assembly, linear low-density rotationally molded polyethylene for field adjustability to optimal installation depth.

SUBMITTAL OPTIONS

- ECA-TZ-29 Extension Collar with additional 29" (73.7 cm) of extension
- TZSP-40-ECA Sampling Port with 4" Inlet/Outlet, 0.5" fall with 29" (73.7 cm) Extension Collar Assembly
- TZSP-48-ECA Sampling Port with 4" Inlet/Outlet, 7.8" fall with 29" (73.7 cm) Extension Collar Assembly
- TSS-70-ECA Solids Interceptor for additional Solids Capacity
- VFCA-75 Vented Flow Control Assembly for installation at plumbing fixture level to limit flow to 75 gpm for installations with head height greater than 6'
- MFSH-44 Molded Flow Splitter Assembly for evenly diverting flow to two separate 4" Trapzilla units
- FTCA-22 Fabricated Top Cover Assembly with diamond plate aluminum surface for heavy duty foot-traffic, pallet jacks, food carts etc. (not rated for vehicle traffic)
- H20/Traffic Rated Installation, see [link](#) for installation drawings